

MINIATURE TYPE

18S Model



Miniature Model

- Small-size Encoder with OD 18mm.
- Shaft Diameter of 2.5mm is Available for OD 18mm House Encoder.



Model

18S- [] - [] - [] -15-00E

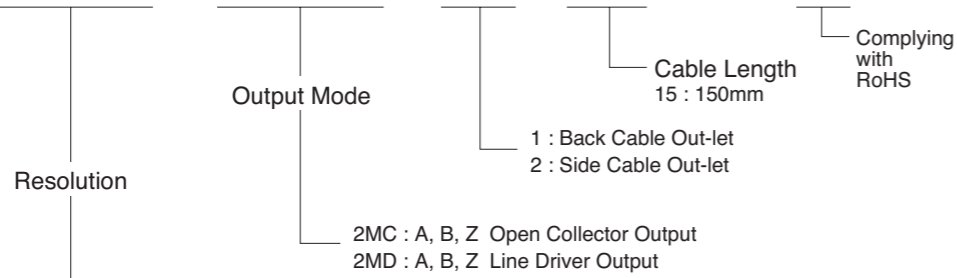

100	100 P/R	360	360 P/R	1000	1000P/R
160	160 P/R	400	400 P/R	1024	1024P/R
200	200 P/R	500	500 P/R	1600	1600P/R
300	300 P/R	800	800 P/R	-	-

External Dimension

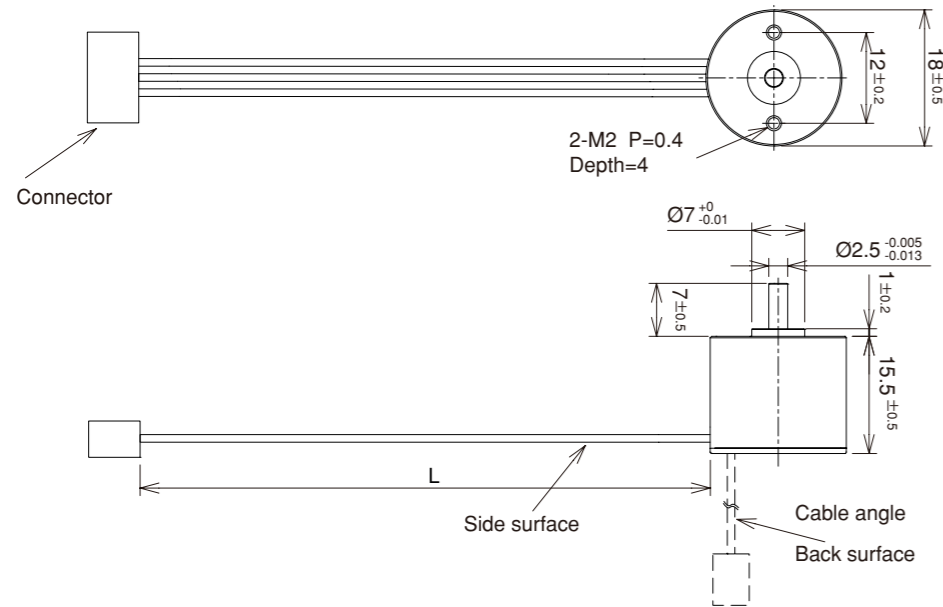

Output Circuit

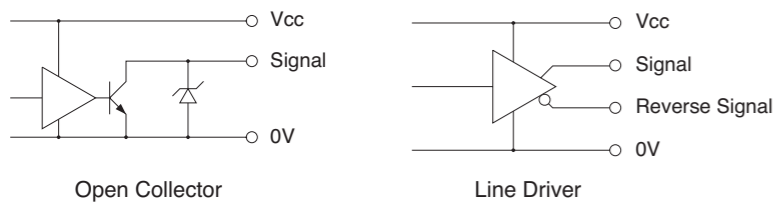

Electrical Spec

TYPE	2MC	2MD
Power Supply(Vcc)	DC 4.5 to 13.2V (Ripple 100mV (P-P))	DC 4.5 to 5.5V (Ripple 100mV (P-P))
Current Consumption	30mA Max	
Output Voltage	"H"	2.5V Min
	"L" *1	0.5V Max
Maximum Sink Current	20mA	
Maximum Frequency Response	400P/R or less	120kHz
	500P/R or more	240kHz
Rise & Fall Time	1µs Max	100ns Max

*1) at Maximum Sink Current

Electrical Connections

Connector Hirose Electric Co., Ltd. DF3-5S-2C

Open Collector		
1	Brown	Vcc
2	Red	0V
3	Orange	Sig A
4	Yellow	Sig B
5	Green	Sig Z

Connector Hirose Electric Co., Ltd. DF3-9S-2C

Line Driver		
1	Brown	Vcc
2	Red	0V
3	Orange	Sig A
4	Yellow	Sig B
5	Green	Sig A
6	Blue	Sig B
7	Purple	Sig Z
8	Gray	Sig Z
9	N.C	N.C

Wave Form

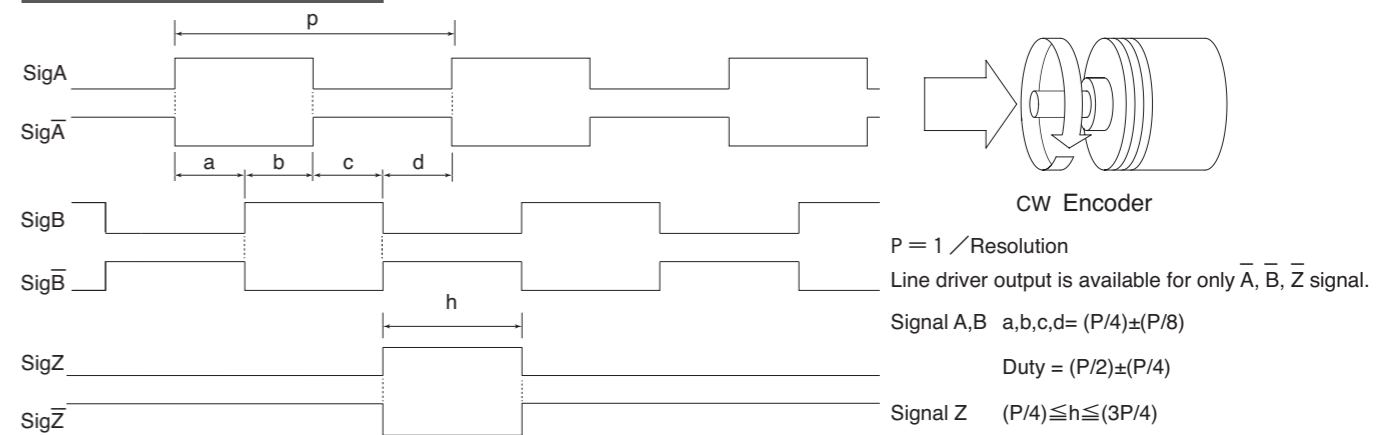

Mechanical Spec

Starting Torque	4.9×10 ⁻⁴ N·m Max	
Shaft Loading	Thrust	4.9N
	Radial	2.94N
Moment of Inertia	1×10 ⁻⁸ kg·m ²	
Angular Acceleration	1×10 ⁻⁵ rad/s ²	
Maximum Permissible Speed	6000min ⁻¹	
Net Weight	20g Max (Without Cable)	

Environmental Spec

Operating Temperature	-10°C~+85°C
Storage Temperature	-30°C~+85°C
Humidity	RH 85% Max No Condensation
Vibration	10~55 Hz / 1.5mm X,Y,Z Each 2h
Shock	490m/s ² , 11ms X, Y, Z Each 3 times
Ingress Protection	IP50